

# High Frequency Lock-In Amplifier

SR844 — 200 MHz, dual phase RF lock-in amplifier



## SR844 200 MHz Lock-In Amplifier

- **25 kHz to 200 MHz frequency range**
- **80 dB dynamic reserve**
- **Time constants from 100  $\mu$ s to 30 ks (6, 12, 18 or 24 dB/oct rolloff)**
- **"No Time Constant" mode (10  $\mu$ s to 20  $\mu$ s update rate)**
- **Auto gain, phase, reserve and offset**
- **Two 16-bit DACs and ADCs**
- **Internal or external reference**
- **GPIB and RS-232 interfaces**

• **SR844 ... \$7950 (U.S. list)**

The SR844 is the widest bandwidth lock-in amplifier available. Unlike simple down-converters, no additional instruments are required. And unlike analog lock-ins, no manual frequency range switching is necessary.

The SR844 provides uncompromised performance with a frequency range of 25 kHz to 200 MHz and up to 80 dB of drift-free dynamic reserve. It includes the many features, ease of operation and programmability that you've come to expect from SRS DSP lock-in amplifiers.

### Digital Technology

The SR844 uses the same advanced DSP technology found in the SR850, SR830 and SR810 lock-in amplifiers. DSP offers many advantages over analog instruments—high dynamic reserve, low zero-drift, accurate RF phase shifts and orthogonality, and digital output filtering.

### Signal Input

The SR844 has both 50  $\Omega$  and 1 M $\Omega$  inputs. The 1 M $\Omega$  input is used with high source impedances at low frequencies, or with a standard 10 $\times$  scope probe. The 50  $\Omega$  input provides the best RF signal matching. Up to 60 dB of RF attenuation or 20 dB of RF gain can be selected in 20 dB increments. Full-scale sensitivities range from 1 Vrms (+13 dBm) to 100 nVrms (-127 dBm). Gain allocation can be optimized to provide up to 80 dB of dynamic reserve.

## Reference

The SR844 offers both external and internal reference operation. In both cases, the entire 25 kHz to 200 MHz frequency range is covered without any manual range selection. The external reference input has an auto-threshold feature which locks to sine, square or pulsed signals. The internal reference is digitally synthesized and is adjustable with 3-digit frequency resolution.

Harmonic detection of the 2F component is available for both internal and external reference modes.

A reference output (1.0 Vpp square wave into 50  $\Omega$ ), which is phase synchronous with the lock-in reference, is available in both external and internal mode.

## Output Filters

Time constants from 100  $\mu$ s to 30 ks can be selected with a choice of 6, 12, 18 or 24 dB/oct rolloff. For high bandwidth, real-time outputs, the filtering can be by-passed entirely. In this "No Filter" mode, the effective time constant is about 30  $\mu$ s with the analog outputs updating every 10 to 20  $\mu$ s.

## Ease of Operation

The SR844 is easy to use. All instrument functions are set from the front-panel keypad, and the knob is used to quickly adjust parameters. Up to nine different instrument configurations can be stored in non-volatile memory for fast, reliable instrument setup. Standard RS-232 and GPIB (IEEE-488.2) interfaces provide connections to your data acquisition systems.

## Useful Features

Auto-functions allow parameters that are frequently adjusted to be set automatically. Sensitivity, dynamic reserve, phase and offset are each quickly optimized with a simple key stroke.

The offset and expand features are useful for evaluating small fluctuations in your signal. The input is nulled with the auto-offset function and output expand increases the resolution by up to 100 $\times$ .

Ratio mode is used to normalize the signal to an externally applied analog voltage. It is useful to eliminate the effect of source intensity fluctuations.

Transfer function measurements can be easily made from the front panel by a programmable scan of up to 11 frequencies. Setups and offsets are recalled at each frequency in the scan.

## Analog Inputs and Outputs

The two displays each have a user-defined output for measuring X, Y, R, R(dBm),  $\theta$ , and X-noise or Y-noise. Two user-programmable DACs provide  $-10.5$  V to  $+10.5$  V outputs with 1 mV resolution. These outputs may be set from the front panel or via the computer interfaces.

In addition, there are two general-purpose analog inputs. These are 16-bit ADCs which can be displayed on the front panel, read over the interface or used to ratio the input signal.

## Internal Memory

The SR844 has two 16,000 point memory buffers for recording (rates to 512 samples/s) the time history of each displayed measurement. Data may be transferred from the buffers using either interface. A trigger input is also provided to synchronize data recording with external events.

## Ordering Information

SR844	200 MHz dual phase lock-in amplifier (w/ rack mount)	\$7950
SR445	Voltage preamplifier (300 MHz, 4 channel)	\$1100



SR844 rear panel

**Signal Channel**

Voltage input	Single-ended BNC
Input impedance	50 $\Omega$ or 1 M $\Omega$ + 30 pF
Damage threshold	$\pm 5$ V (DC + AC)
Bandwidth	25 kHz to 200 MHz
Sensitivity	
<1 MHz	100 nVrms to 1 Vrms full scale
<50 MHz	1 $\mu$ Vrms to 1 Vrms full scale
<200 MHz	10 $\mu$ Vrms to 1 Vrms full scale
Gain accuracy	
<50 MHz	$\pm 0.25$ dB
<200 MHz	$\pm 0.50$ dB
Gain stability	0.2 %/°C
Coherent pickup	Low-noise reserve, sens. <30 mV
f <10 MHz	<100 nV (typ.)
f <50 MHz	<2.5 $\mu$ V (typ.)
f <200 MHz	<25 $\mu$ V (typ.)
Input noise (50 $\Omega$ )	2 nV/ $\sqrt{\text{Hz}}$ (typ.), <8 nV/ $\sqrt{\text{Hz}}$ (max.)
Input noise (1 M $\Omega$ )	5 nV/ $\sqrt{\text{Hz}}$ (typ.), <8 nV/ $\sqrt{\text{Hz}}$ (max.)
Dynamic reserve	up to 80 dB

**Reference Channel**

External reference	25 kHz to 200 MHz
Impedance	50 $\Omega$ or 10 k $\Omega$ + 40 pF
Level	0.7 Vpp pulse or 0 dBm sine
Pulse width	>2 ns at any frequency
Threshold setting	Automatic, midpoint of waveform
Acquisition time	<10 s (auto-ranging, any frequency)
Internal reference	25 kHz to 200 MHz
Freq. resolution	3 digits
Freq. accuracy	$\pm 0.1$ in the 3 <sup>rd</sup> digit
Harmonic detection	2F (50 kHz to 200 MHz)
Reference outputs	Phase locked to int./ext. reference
Front panel	25 kHz to 200 MHz square wave 1.0 Vpp nominal into 50 $\Omega$
Rear panel (TTL)	25 kHz to 1.5 MHz, 0 to +5 V nominal, $\geq 3$ V into 50 $\Omega$
Phase resolution	0.02°
Absolute phase error	
<50 MHz	<2.5°
<100 MHz	<5.0°
<200 MHz	<10.0°
Rel. phase error, orthog.	<2.5°
Phase noise (external)	0.005° rms at 100 MHz, 100 ms time constant
Phase drift	
<10 MHz	<0.1°/°C
<100 MHz	<0.25°/°C
<200 MHz	<0.5°/°C

**Demodulator**

Zero stability	Digital displays have no zero-drift. Analog outputs have <5 ppm/°C drift for all dyn. reserve settings.
Time constants	100 $\mu$ s to 30 ks with 6, 12, 18 or 24 dB/octave rolloff
"No Filter" mode	10 to 20 $\mu$ s update rate (X and Y)

Harmonic rejection	
Odd harmonics	-9.5 dBc @ 3 $\times$ ref, -14 dBc @ 5 $\times$ ref, etc. (20 log 1/n, n = 3, 5, 7...)
Even harmonics	< -40 dBc
Sub-harmonics	< -40 dBc
Spurious responses	-10 dBc @ref $\pm 2 \times$ IF -23 dBc @ref $\pm 4 \times$ IF < -30 dBc otherwise

**Displays**

Channel 1	
Type	4½-digit LED and 40-seg. bar graph
Quantities	X, R (V or dBm), X-noise, Aux In 1
Channel 2	
Type	4½-digit LED and 40-seg. bar graph
Quantities	Y, $\theta$ , Y-noise (V or dBm), Aux In 2
Expand	$\times 10$ or $\times 100$ for Ch1 and Ch2
Ratio	X and Y ratioed with respect to Aux In 1 or Aux In 2 before filtering and computation of R. The ratio input is normalized to 1 V and has a dynamic range greater than 100.
Reference	
Type	4½-digit LED
Quantities	Ref Freq, Phase, Offsets, Aux Out, IF Freq, Elapsed Time

**Channel 1 and Channel 2 Outputs**

Voltage range	$\pm 10$ V full scale proportional to X, Y or CH1, CH2 displayed quantity
Update rate	
X, Y	48 to 96 kHz
R, $\theta$ , Aux inputs	12 to 24 kHz
X-noise, Y-noise	512 Hz

**Auxiliary Inputs and Outputs**

Inputs	2
Type	Differential, 1 M $\Omega$
Range	$\pm 10$ V
Resolution	0.33 mV
Bandwidth	3 kHz
Outputs	2
Range	$\pm 10$ V
Resolution	1 mV
Data buffers	Two 16,000 point buffers. Data is recorded at rates up to 512 Hz and is read using computer interfaces.

**General**

Interfaces	IEEE-488.2 and RS-232 interfaces are standard.
Power	70 W, 100/120/220/240 VAC, 50/60 Hz
Dimensions	17" $\times$ 5.25" $\times$ 19.5" (WHD)
Weight	23 lbs.
Warranty	One year parts and labor on defects in materials and workmanship

**About RF Lock-In Amplifiers**

The SR844 RF lock-in amplifier utilizes a combination of analog and digital techniques to obtain maximum performance over a wide frequency range. Since it is not feasible to use pure digital techniques at the SR844's maximum 200 MHz operating frequency, analog down-conversion is used to transform the signal frequency to a range suitable for DSP processing.

A block diagram of the SR844 lock-in amplifier is shown below. The RF input signal passes through adjustable RF attenuators and gain stages depending on the selected input sensitivity. The signal is then mixed with two reference signals which differ in phase by 90°.

The reference signals are generated from either the external reference input or the built-in frequency synthesizer, using a phase-lock loop (PLL) circuit. If the reference frequency were exactly at the signal frequency, the output of the mixers would be at DC. Since it is difficult to build drift and offset free amplifier chains, the SR844 chops the reference signals at a chopping frequency ( $f_c$ ) which is chosen to be fast relative to the fastest time constants, yet slow relative to the input signal frequency. The IF amplifier and filter chain can now be AC coupled, eliminating DC offset and drift problems.

Once the in-phase and quadrature IF signals have been amplified and low-pass filtered, the signals are digitized by two precision 16-bit analog-to-digital converters. The digital IF signals are ratioed (if ratio mode is selected) and digitally

low-pass filtered (with 6, 12, 18 or 24 dB/oct filter slopes) allowing the original signal amplitude and phase to be recovered.

Note that the SR844 uses a square wave mixer, not a sine wave mixer like other SRS lock-in amplifiers. This is because precision sine generation is impractical with current technology over the SR844's operating range. The effect of using a square wave mixer is that the lock-in will respond not only at the reference frequency, but at all the Fourier components of the square wave reference. Since a square wave consists of odd harmonics with amplitudes 1/3, 1/5, 1/7, etc., the SR844 will respond at odd multiples of the reference frequency as well as at the reference frequency as itself. This usually does not present a problem as long as it is understood.

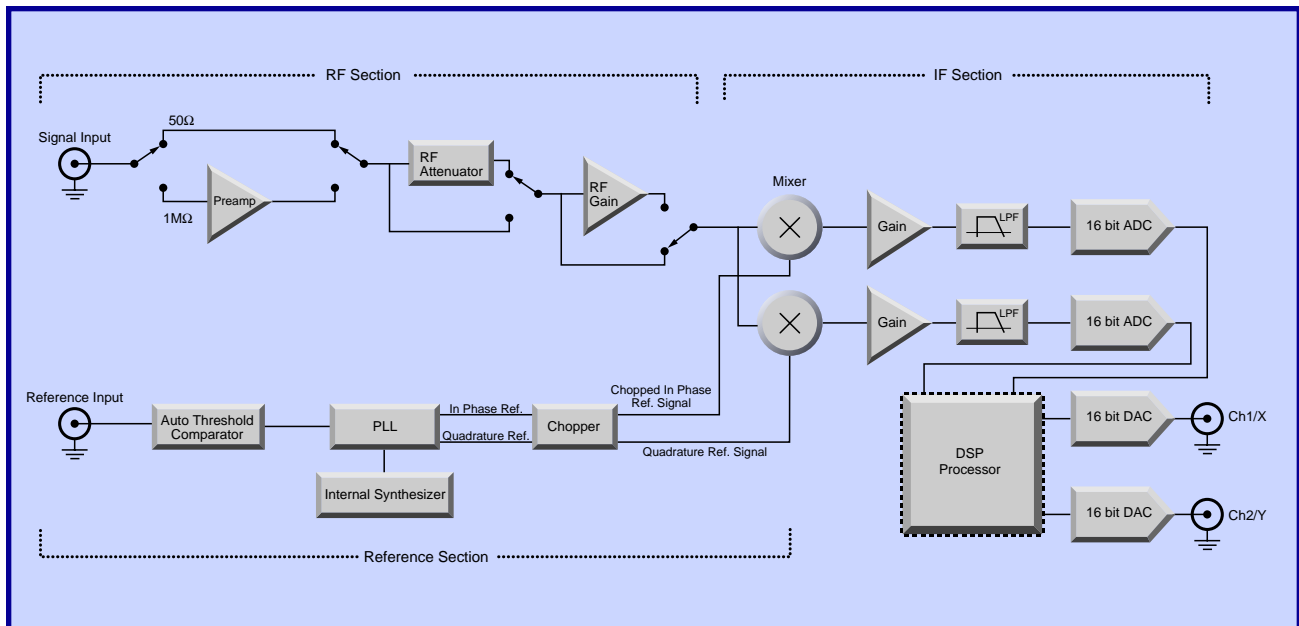

**SR844 block diagram**